

# LTECH

## DMX512 DECODER

LT-932

**32**  
CHANNEL

8 bit / 16 bit

4 kinds of DMX interfaces

Short circuit / Over current / Overheat protection

C **UL** US  
E500585

**RDM**   
**DMX**



Photoelectric  
isolation

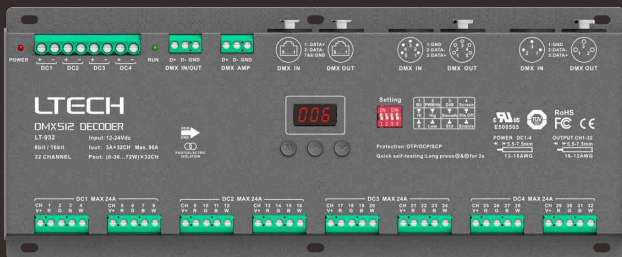

[www.ltech-led.com](http://www.ltech-led.com)

## Product introduction

1. Designed for Hi-power multiple channels application, 32 channels output, and up to 2304W output power.
2. Easy operation with digital display and the touch buttons.
3. 3-pin XLR, 5-pin XLR, RJ45 and green terminal DMX interface with photoelectric isolation, improve signal transmission efficiency and anti-interference ability, the green terminal also has signal amplifier function.
4. With RDM remote management protocol, the operations can be completed via the RDM master console, such as parameters browsing & settings, DMX address settings, equipment recognition, etc.
5. With short circuit / overheat / over current protection, as well as warning function when a fault occurs.
6. With firmware upgrade function.
7. With fast self-testing function.
8. High/low PWM frequency available.
9. 16bit (65536 levels) / 8bit (256 levels) grey level available.



3-pin XLR



5-pin XLR



RJ45



RDM

Photoelectric  
isolationShort circuit  
protectionOverheat  
protectionOver current  
protection

## Technical specs

Model :	LT-932
Input signal :	DMX512/RDM
Input voltage :	12-24Vdc
Current load :	3A × 32CH Max. 96A
Output power :	(0-36W...72W) × 32CH Max. 2304W
DMX interfaces :	3-pin XLR, 5-pin XLR, RJ45, Green terminal
Grey level :	8bit (256 levels) / 16bit (65536 levels)
Photoelectric isolation :	Yes
Protection :	Short circuit / Overheat / Over current protection, recover automatically.
Working temperature :	-30°C-65°C
Dimensions :	300×122×39mm(L×W×H)
Package size :	313×127×41mm(L×W×H)
Weight (G.W.) :	1180g



## Product size

Unit: mm

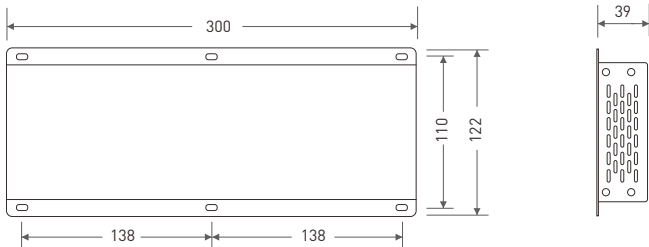

# Main component description

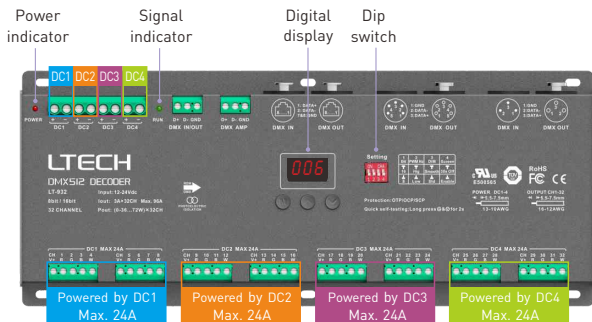

## Digital display



- Digital display will enter the locked mode without operating after 15s.
- Long press "M" key to unlock.
- Short press "M" key to switch numbers.
- Press " ^ " " v " key to adjust value.

## Dip switch



1	2	3	4
1 Bit	PWM Hz	DIM	Screen
⌵	⌵	⌵	⌵
16	High	Smooth	30S off
⌴	⌴	⌴	⌴
8	Low	Std	Enable

\* Fast self-testing function: press " ^ " or " v " keys simultaneously for 2-3 seconds under any page, decoder will enter self-testing function.

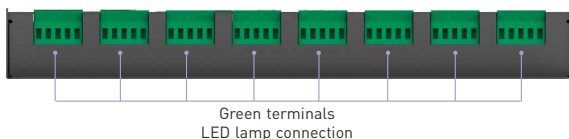
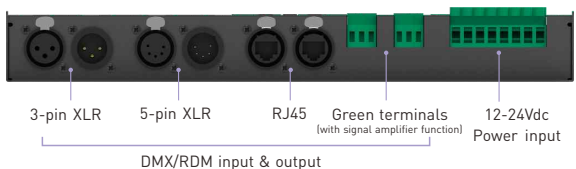

## Wiring diagram

### 1. DMX console connection:

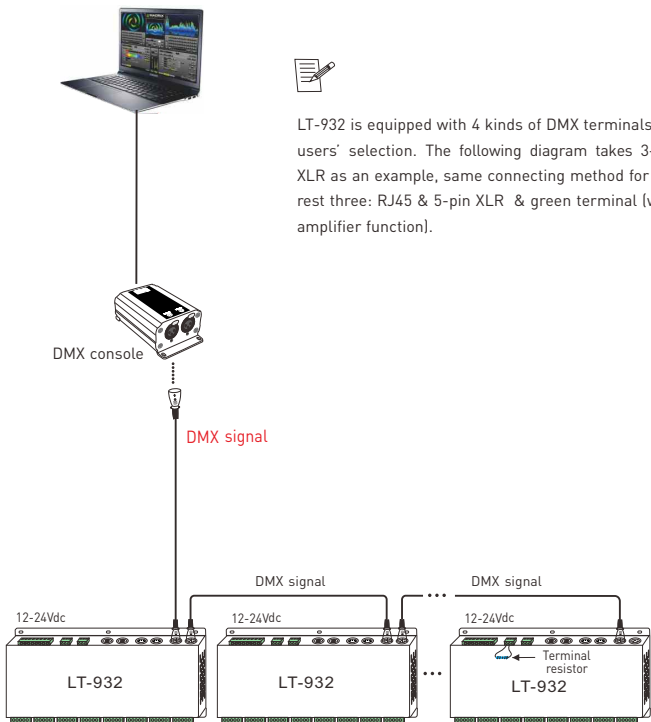

LT-932 is equipped with 4 kinds of DMX terminals for users' selection. The following diagram takes 3-pin XLR as an example, same connecting method for the rest three: RJ45 & 5-pin XLR & green terminal (with amplifier function).

If the recoil effect occurs because of longer signal line or bad line quality, please try to connect 0.25W 90-120Ω terminal resistor at the end of each line.

## 2. Connecting LED lights:

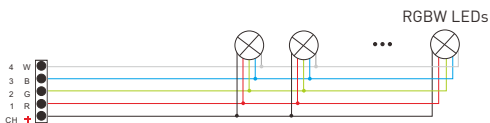
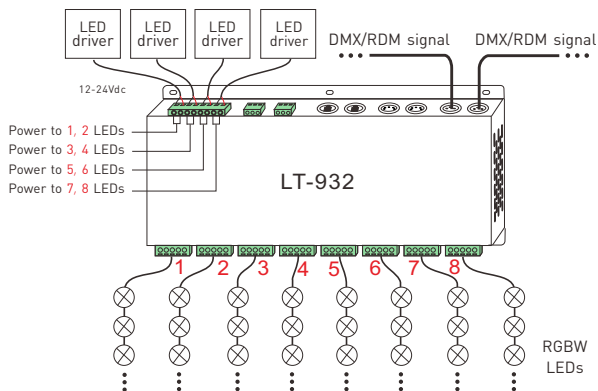
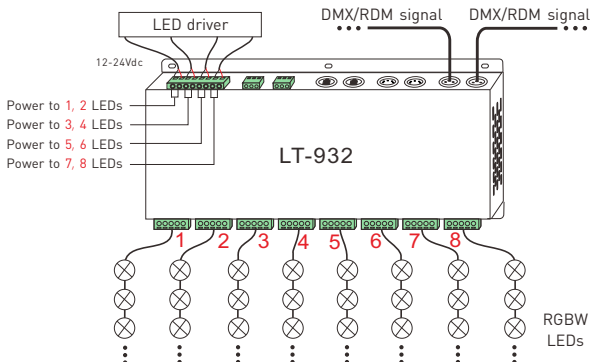

### 3. The connection diagram of 4 kinds of DMX/RDM terminals:

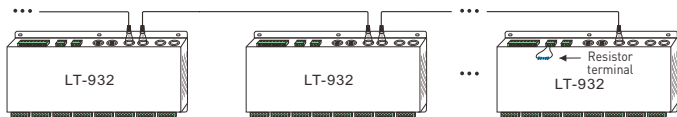

5-pin XLR connected in parallel

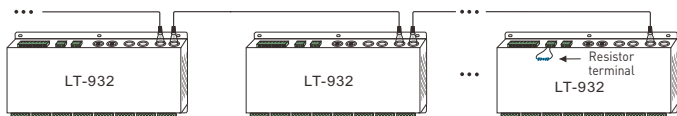

3-pin XLR connected in parallel

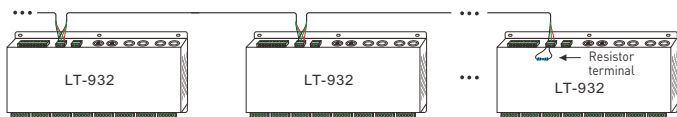

Green terminal connected in parallel

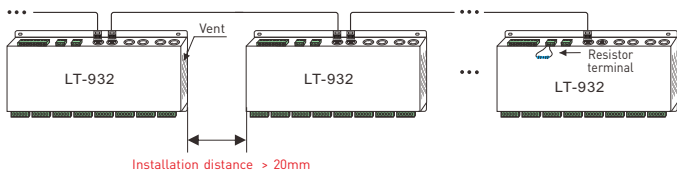

RJ45 connected in parallel

These 4 terminals can be connected in a mixed way.

**Installation attentions :** please reserve enough ventilation distance between decoders (>20mm), be sure not to block the vent, or it will affect lifetime of decoder for poor heat dissipation.

#### 4. The connection diagram of AMP signal amplifier terminal:

Connecting with green terminal or an extra amplifier will be needed when more than 32 decoders are connected or use overlong signal wire (as shown below).

Signal amplifier should not be more than 5 times continuously.

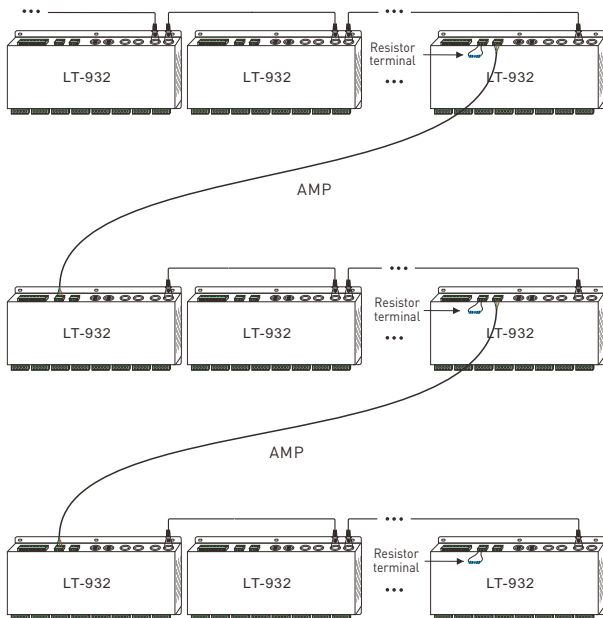



## Work with RDM editor

LT-932 can work with LTECH RDM editor (Model: WiFi-RDM01) to realize changing the parameters and firmware upgrade by long-range setting, wiring diagram as below:

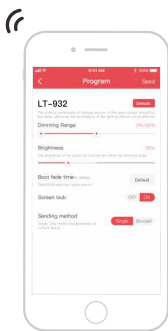
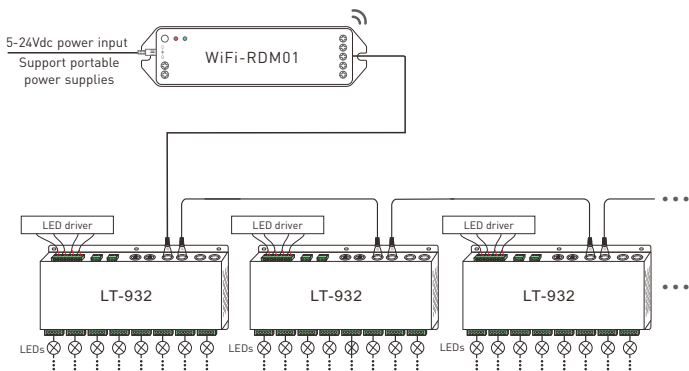

## RDM editor App interface instruction

Download the App, setting LT-932 parameters (dimming range, brightness, boot fade time etc.) after well connecting the RDM editor, more details, please check the manual of WiFi-RDM01.

Well installation of products first, then working with WiFi-RDM01 to realize setting parameters and firmware upgrade by App.

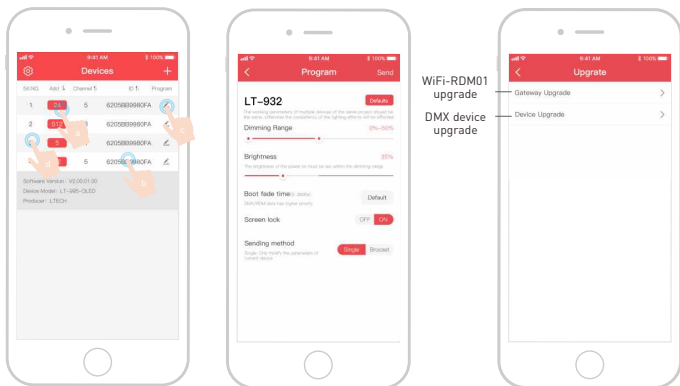

WiFi-RDM01  
upgrade  
DMX device  
upgrade

- a: Click "Add", edit the address in corresponding box.
- b: Click "ID", get more product details.
- c: Click " ", enter edited interface.
- d: Click "No.", issue the recognizing command.

Supporting WiFi-RDM01 upgrade  
and DMX driver upgrade.

## Attentions

1. Products shall be installed by qualified professionals.
  2. LTECH products are non-waterproof (special models excepted). Please avoid the sun and rain. When installed outdoors, please ensure it is mounted in a water proof enclosure.
  3. Good heat dissipation will extend the working life of products. Please ensure good ventilation.
  4. Please check if the working voltage used complies with the parameter requirements of products.
  5. The diameter of wire used must be able to load the light fixtures you connect and ensure the firm wiring.
  6. Before you power on products, please make sure all the wiring is correct in case of incorrect connection that causes damage to light fixtures.
  7. If a fault occurs, please do not attempt to fix products by yourself. If you have any question, please contact your suppliers.
- \* This manual is subject to changes without further notice. Product functions depend on the goods. Please feel free to contact our official distributors if you have any question.

## Warranty agreement

Warranty periods from the date of delivery : 5 years.

Free repair or replacement services for quality problems are provided within warranty periods.

Warranty exclusions below:

- Beyond warranty periods.
  - Any artificial damage caused by high voltage, overload, or improper operations.
  - Products with severe physical damage.
  - Damage caused by natural disasters and force majeure.
  - Warranty labels and barcodes have been damaged.
  - No any contract signed by LTECH.
1. Repair or replacement provided is the only remedy for customers. LTECH is not liable for any incidental or consequential damage unless it is within the law.
  2. LTECH has the right to amend or adjust the terms of this warranty, and release in written form shall prevail.

# LTECH 雷特

## DMX512 DECODER

LT-932

**32**  
CHANNEL

8 bit / 16 bit  
4种DMX接口  
短路、过温、过流保护

C **UL** **US**  
E500585

RDM   
DMX

光电隔离

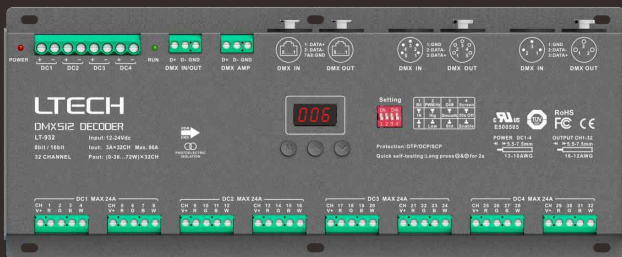

[www.ltech.cn](http://www.ltech.cn)

## 产品介绍

- 1、本产品为大功率多通道应用而设计，共有32个通道输出，总功率可高达 2304W。
- 2、使用数码管和轻触按键设置地址码，操作简单快捷。
- 3、提供3针XLR、5针XLR、绿色端子、RJ45四种具有光电信号隔离功能的DMX接口，提高信号传输效率和抗干扰能力，其中绿色端子还有信号放大功能。
- 4、具有RDM远程管理协议，通过RDM主控可对其进行参数浏览与设置、DMX地址修改、设备识别等操作。
- 5、具有固件升级功能。
- 6、具有短路、过温、过流自动保护与恢复功能，并有故障警示提示功能。
- 7、快速测试功能。
- 8、PWM频率可选高频/低频。
- 9、16bit(65536级)/8bit(256级)灰度级可选。



3针XLR



5针 XLR



RJ45



RDM



光电隔离



短路保护



过流保护



过温保护

## 性能参数

产品型号：	LT-932
输入信号：	DMX/RDM
输入电压：	12- 24Vdc
负载电流：	3A×32路 Max. 96A
输出功率：	[0~36W...72W]×32路 Max. 2304W
DMX接口：	3针XLR, 5针XLR, RJ45, 绿色端子
灰度等级：	8bit(256级)/16bit(65536级)可选
光电隔离：	有
保护：	短路、过温、过流保护，可自动恢复
工作温度：	-30°C~65°C
产品尺寸：	L300×W122×H39mm
包装尺寸：	L313×W127×H41mm
重量(毛重)：	1180g



## 产品尺寸

单位: mm

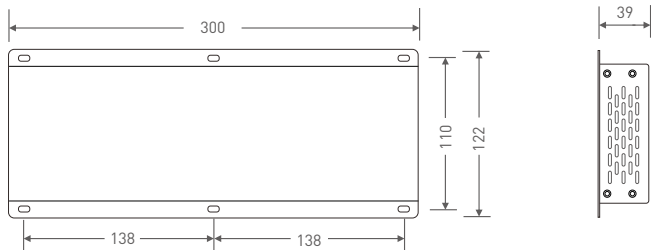

## 部件图

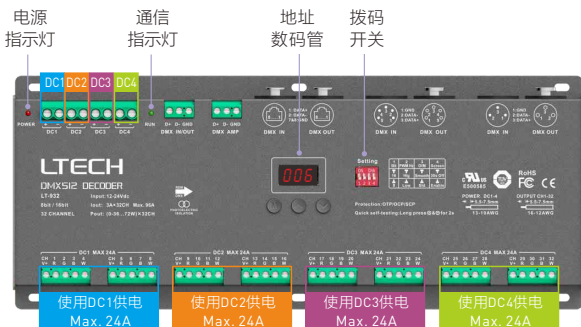

## 地址数码管



M ^ v

- 数码管不使用15秒将进入锁定状态
- 长按“M”键解锁
- 短按“M”键切换至另一数字
- 按“^”“v”键调整数值

## 拨码开关



1 灰度级	2 PWM Hz	3 调光	4 显示
T 16	T 高	T 平滑	T 30秒后关
⬇ 8	⬇ 低	⬇ 标准	⬇ 开

\* 快速自测功能: 任何界面下, 同时按 ^ 或 v 键2~3秒, 解码器会进入自我测试功能。

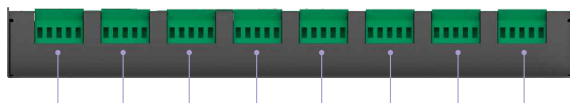

## 连接示意图

### 1. DMX系统连接

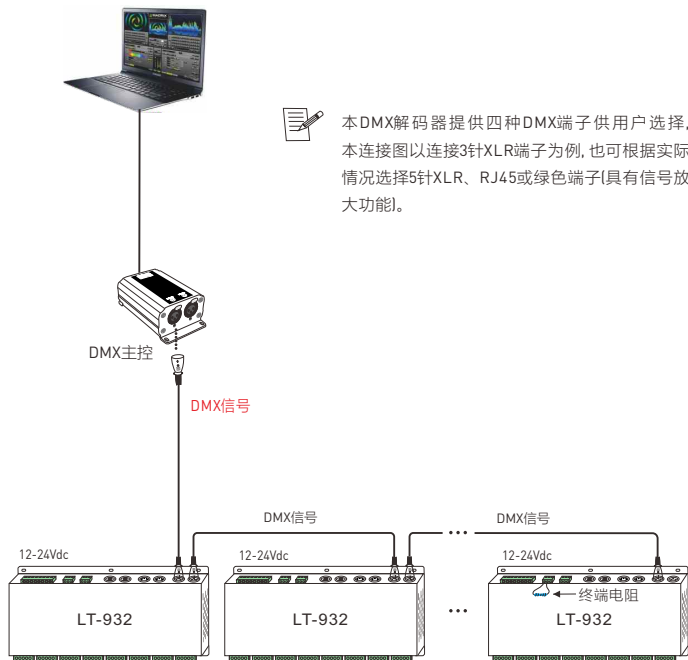

本DMX解码器提供四种DMX端子供用户选择, 本连接图以连接3针XLR端子为例, 也可根据实际情况选择5针XLR、RJ45或绿色端子(具有信号放大功能)。

\* 当信号线较长或者线材质量等原因造成信号反冲效应影响使用, 可以尝试在每路信号线末端连接0.25W 90-120Ω终端电阻解决。



## 2. 连接LED灯

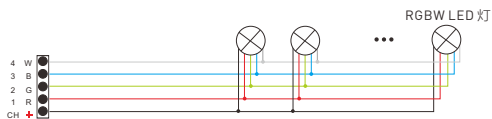
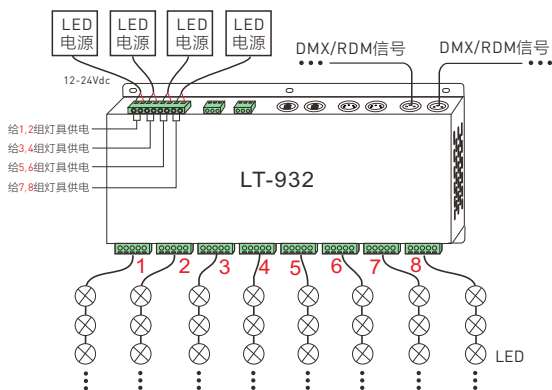
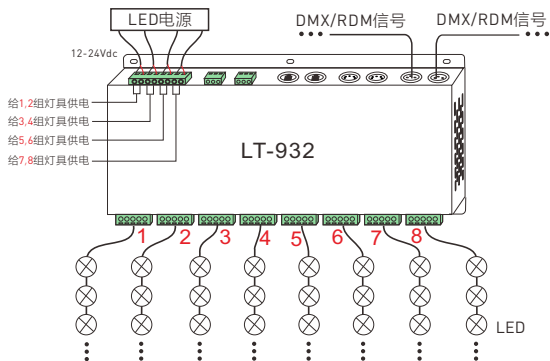

## 3 四种DMX端口的连接示意图

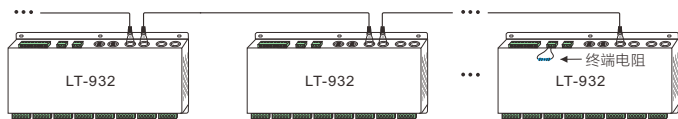

5针XLR并联连接

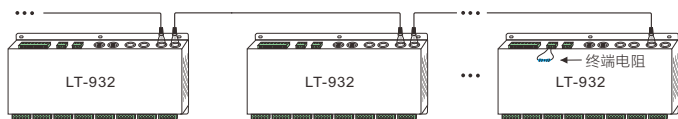

3针XLR并联连接

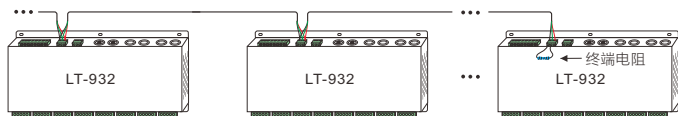

绿色端子并联连接

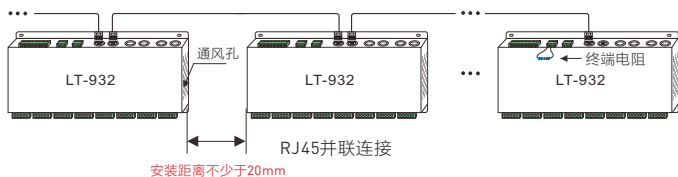

以上四种方式可以任意混合连接

\* 安装注意事项：请在解码器与解码器之间预留通风距离（最少20mm），切勿堵塞通风孔，否则会因设备散热不畅影响使用寿命。

#### 4 AMP信号放大端子连接图

\* 当DMX解码器过多(超过32台),或信号线过长,需加信号放大器或使用绿色端子接口进行信号放大(见下图),信号放大不能连续超过5次。

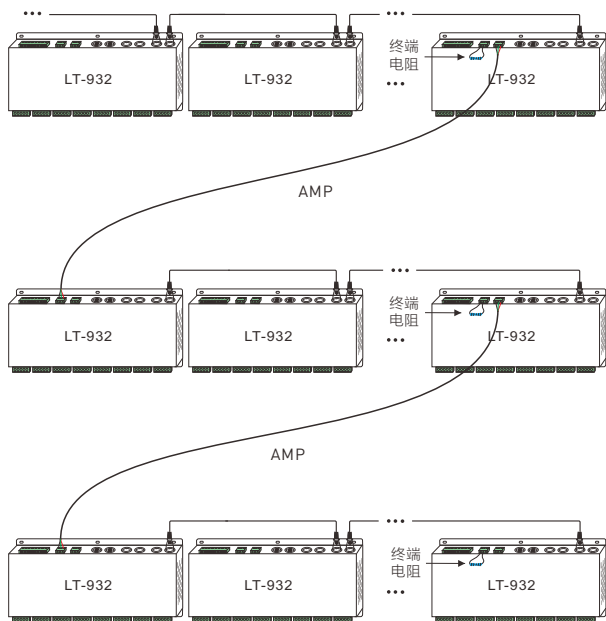

## 与RDM编辑器配合使用

LT-932可以与我司RDM编辑器（型号WiFi-RDM01）配合使用，以实现手机远程浏览与设置参数、固件升级等，连接图如下：

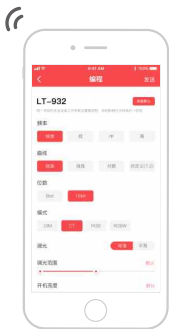
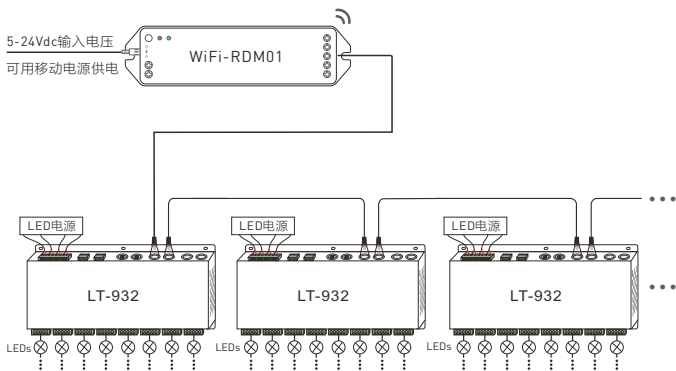

## RDM编程器APP界面介绍

手机下载APP，与RDM编辑器连接成功后，即可通过APP设置LT-932的调光范围、开机亮度、开机渐变时间等参数，具体请参看WiFi-RDM01的使用说明书。

配套使用WiFi-RDM01后，即可实现先安装再用APP设置参数及进行固件升级，随心更改，免高空作业。

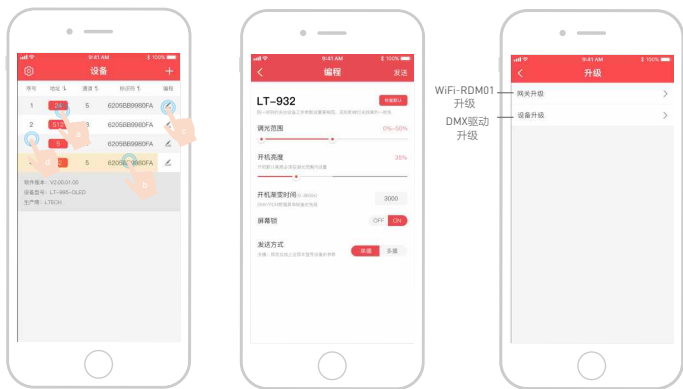

- a：点击“地址”对应方框可编辑地址；
- b：点击“标识符”出现产品详细信息；
- c：点击编程按钮“编程”则进入编辑界面；
- d：点击序号发出识别命令。

在APP进行固件升级

## 注意事项

- 1、本产品请由具有专业资格的人员进行调试安装。
  - 2、雷特产品（专有型号除外）不能防水，需避免日晒雨淋，如安装在户外，请用防水箱。
  - 3、良好的散热条件会延长产品的使用寿命，请把产品安装在通风良好的环境。
  - 4、请检查使用的工作电压是否符合产品的参数要求。
  - 5、使用的电线直径大小必须能够负载连接的LED灯具，并确保接线牢固。
  - 6、通电调试前，应确保所有接线正确，以避免因接线错误而导致灯具损坏。
  - 7、如果发生故障，请勿私自维修；如有疑问，请联系供应商。
- \* 本说明书的内容如有变更，恕不另行通知。若内容与您使用的功能有所不同，则以实物为准。如有疑问，欢迎向我司授权的经销商咨询。

## 保修条例

- 自出厂之日起保修服务期为5年。
- 在保修服务期内出现产品质量问题雷特将给予免费修理或更换服务。

### 非保修条例:

属下列情况不在免费保修或更换服务范围之内:

- 已经超出保修服务期;
  - 过高电压、超负载、操作不当等人为造成的损坏;
  - 产品外形严重损坏或变形;
  - 自然灾害以及人力不可抗拒原因造成的损坏;
  - 产品保修标签和产品唯一条形码损坏;
  - 无雷特签订的合同或发票凭证。
1. 修理或更换是雷特对客户的唯一补救措施。雷特不承担任何附带引起的损害赔偿 responsibility, 除非在适用法律范围之内。
  2. 雷特享有修正或调整本保修条款的权利, 并以书面形式发布为准。